



H3O

Hurley's 3rd Option



INSTRUCTION MANUAL

WARNINGS

WARNING - Extreme Caution should be used when operating this system . . .

Failure to install, maintain, protect, and operate the system properly can cause malfunction resulting in possible serious or fatal injuries and/or property damage.
Not to be operated by children.

WARNING - Davit system is not intended to be used with any person(s) and/or possessions in the dinghy.

WARNING - Do not attempt to operate system while boat is under power.

WARNING - System should not be placed in an area where the prop, outdrive or any other mechanical part may come in contact.

WARNING - Remove drain plug from tender when on davit.

WARNING - A dinghy cover is recommended to keep water from entering the dinghy.

WARNING - Do not drill holes in your davit or alter in any way.

WARNING - Only use stainless steel hardware when mounting and use a backing plate when applicable.

WARNING - Dinghy must be secured /tied down before transporting.

WARNING - Remove and stow winch when not in use.

WARNING - Contact the manufacturer of your swim platform to ensure that it is able to handle the added weight.

WARNING - Regular inspection, adjustment, and maintaining your davit and other associated components is necessary to ensure proper operation.

WARNING - Always clean the davit system with fresh water when it is used in a corrosive environment to maintain longevity.

CAUTION: - It is suggested to off-set the davit, during installation, on the platform so that the stern of the dinghy is more supported due to weight of motor, etc.

CAUTION - Weight limit: 400 pound safe working load. *Do not exceed weight load limit.*

Your *Hurley H30 Dinghy Davit* system is made of Marine Grade High Density Polyethylene and stainless steel components and hardware. All of these components are used for strength, longevity and to reduce friction during retrieval and launching.

Planning the installation: A mounting template has been included with these instructions and should be used to properly a-line, drill and install the mounting plates. You may want to offset the davit on the platform so that the stern of the dinghy is more supported due to weight of motor, etc. Of course this depends on many factors, including, but not limited to, the beam of your boat, length of your dinghy and any obstructions. *Note:* The davit must be able to pivot over the edge of your platform.

Mounting the Plates: It is suggested to use four Stainless Steel 5/16" Button Head Socket Cap Screws (*not included*). Using the Mount Template center punch each hole. Start with a small drill bit and increase bit size to 5/16". It is good practice to use tape on the surface to be drilled then drill the hole through the tape, this will avoid scratching/chipping of the surrounding surface. *Measure twice, drill once!*

Generously apply 3M 5200 sealant to seal drilled holes and the bottom of the mounting plates. Secure fasteners using nylock nuts, fender washers or backing plates, when applicable, and nyloc nuts when thru bolting. Do not apply more than 8-10 foot-pound (ft-lbf) of torque.

Bottom Plate may be rotated by 180°, if space permits, to bring load inward for heavier loads or to help reduce shock loads.

Tie downs must be used when underway, we recommend our 3-Point or 4-Point Tie Down systems for best results.

There is a third mounting pin included with your H30 Davit. It can be used as a replacement pin for mounting or can be used to stop the rotation of the davit, only if there is no tender on the davit system, by inserting it in the hole of the plate. This should only be used when transporting the davit with no tender atop as so it doesn't rotate and drag in the water.

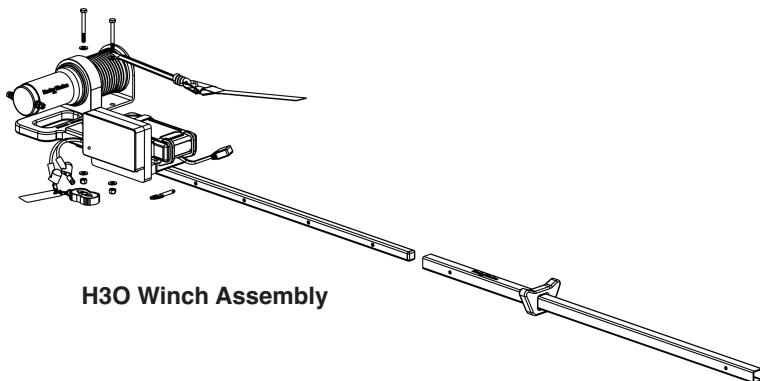

H30 Winch Assembly

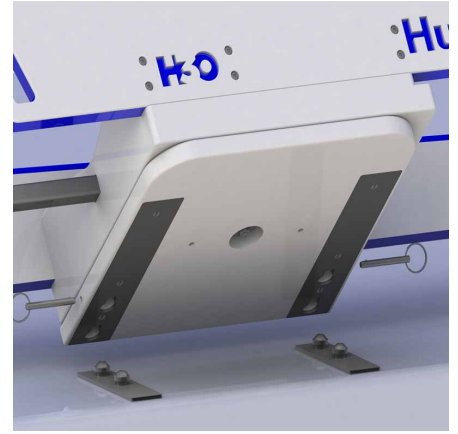

Inspection and tightening of screws, nuts and bolts should be performed weekly. Always clean the davit system with fresh water when it is used in a corrosive environment.

LIMITED WARRANTY AND LIMITATION OF LIABILITY

All new products manufactured under Hurley Marine, Inc., are warranted to be free from defects in material and workmanship under normal and proper use for a period of (2) two years, electric & manual winches, and electrical components 90 days, from date of shipment from Hurley Marine, Inc. No claim for breach of warranty will be allowed unless the material or workmanship is found defective within the warranty period, properly documented by buyer and Hurley Marine, Inc. is notified in writing within 10 days from failure. This warranty shall not apply to products that have been disassembled, altered, or utilized in a manner not approved by Hurley Marine, Inc. or subjected to normal wear and tear, abuse, misuse, improper maintenance, negligence or accident.

CUSTOMER AGREES THAT USE OF THE PRODUCT/SERVICE IS ENTIRELY AT CUSTOMER'S OWN RISK. THE FOREGOING WARRANTIES ARE EXCLUSIVE AND ARE ACCEPTED BY BUYER IN LIEU OF ANY AND ALL OTHER WARRANTIES, EXPRESSED OR IMPLIED, INCLUDING WITHOUT LIMITATION THE IMPLIED WARRANTIES OF MERCHANTABILITY OR FITNESS FOR PARTICULAR PURPOSE. Buyer's sole remedy in the event of a breach of the foregoing warranties is the repair or replacement of the affected product by Hurley Marine, Inc., upon the return of the product transportation charges prepaid to Hurley Marine, Inc., and after a charge to buyer for the use of the product prior to its return. BUYER AGREES THAT IN NO EVENT WILL HURLEY MARINE, INC'S LIABILITY FOR ALL LOSSES FROM ANY CAUSE, WHETHER BASED ON CONTRACT, NEGLIGENCE, STRICT LIABILITY, OTHER TORT OR OTHERWISE, EXCEED BUYER'S NET PURCHASE PRICE, NOR WILL HURLEY MARINE, INC, BE LIABLE FOR ANY SPECIAL, INCIDENTAL CONSEQUENTIAL OR EXEMPLARY DAMAGES.

Under no circumstances is Hurley Marine, Inc. responsible for reimbursement of expenses related to vessel haul-outs, technician or yard personnel, travel expenses, yacht storage, labor performed during removal and/or replacement of fixture(s), or shipping costs for replacement parts and/or repairs. These are assumed liabilities of the customer and part of the terms of sale between Hurley Marine, Inc. and its customer.

The foregoing warranties will continue in effect for so long as the product is serviced and maintained in accordance with Hurley Marine, Inc. instructions and with genuine Hurley Marine, Inc. manufactured replacement parts. These warranties may not be altered or amended except by a written instrument signed by buyer and a duly authorized officer of Hurley Marine, Inc. For warranty or service assistance contact your Hurley Marine, Inc. dealer.

TERMS OF SALE / SHIPPING

RETURN POLICY: If you are dissatisfied with your purchase, contact us within 30 days from the date of product purchase. Products returned within 30 days of their receipt, unopened in their original packaging and otherwise in new condition will automatically be exchanged or refunded. A minimum fee of 25% of the price of the product will be charged for inspection, repacking and restocking for items not returned in their original condition. Other fees may apply depending upon the condition of the item. Products are not returnable after 30 days.

EXCHANGE / REFUND PROCEDURE:

- All returns must have a copy of a paid invoice, contact information and a brief description of the reason accompanied with the return.
- Properly repack the product in the original packaging and place inside a box suitable for shipping with all the original enclosures, parts, and accessories.
- Return it with **original receipt** and postage pre-paid (we do not accept C.O.D.), add appropriate insurance.
- Shipping and packing fees are non-refundable.

Non-Returnable items: Inflatable boats, installed/mounted items, damaged goods, clearance/discount items, used and/or display items, electrical goods, light bulbs and special ordered items are not returnable, unless defective, and then for repair/replacement only. If the product is defective you must call Hurley Marine, Inc. within 10 days of receipt of the product.

DAMAGES GOODS: We thoroughly inspect all items prior to shipment. We suggest that you also thoroughly inspect the item(s) before accepting delivery. If damage is apparent, refuse delivery or if your parcel is left without a signature and damage is found contact the carrier immediately. Do not discard the box or any packaging materials. Most claims must be filed with the carrier within 10 days of receipt of delivery. Although we take special care to ensure the safe arrival of your merchandise, our responsibility for damage ends when the carrier accepts shipment.